

# DragonBoard™ 820c

## Hardware Manual

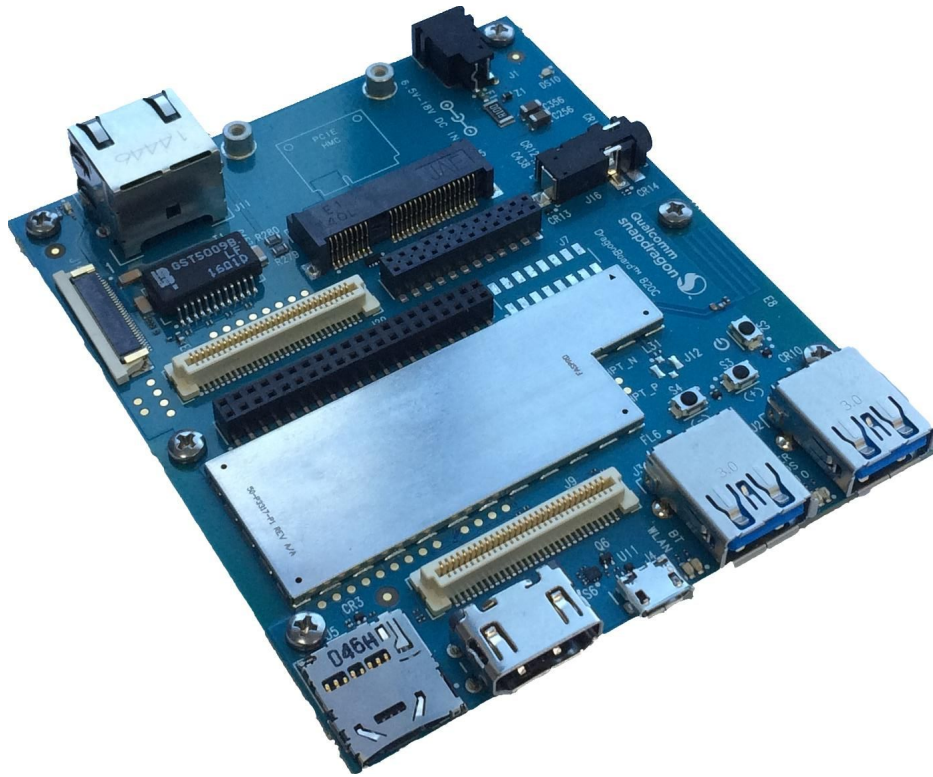

Powered by:



---

# Contents

<b>1</b>	<b>Introduction</b>	<b>5</b>
<b>2</b>	<b>Key features</b>	<b>6</b>
	Board overview	8
<b>3</b>	<b>What's in the Box</b>	<b>9</b>
<b>4</b>	<b>Getting started</b>	<b>10</b>
	Prerequisites	10
	Starting the board for the first time	10
<b>5</b>	<b>DragonBoard Overview</b>	<b>11</b>
	System Block diagram	11
	Processor	11
	Memory	11
	MicroSD	11
	WiFi/BT/RF	11
	Display Interface	12
	HDMI	12
	MIPI-DSI	12
	Camera Interfaces	12
	USB Ports	12
	USB-Host ports	12
	USB-Device port	12
	Audio	13
	BT Audio	13
	HDMI Audio	13
	Input DC-power	13
	Measurements	13
	Buttons	13
	UART13	
	System and user LEDs	13
	Expansion Connector	14
	Additional Functionality	14
	GPS	14
	Ethernet Connector	14
	Mini PCIE connector	14

Inertial Sensors	14
<b>6 Low speed Expansion connector</b>	<b>15</b>
UART {0/1}	16
I2C {0/1}	16
GPIO {A-L}	16
SPI 0 16	
PCM/I2S	16
Power and Reset	16
Power Supplies	17
<b>7 High speed expansion connectors</b>	<b>18</b>
Primary high speed expansion connector	18
MIPI DSI 0	19
MIPI CSI {0/1}	19
I2C {2/3}	19
HSIC	19
Reserved	19
SD/SPI	20
Clocks	20
USB	20
Secondary High Speed Connector	20
Feature information	21
MIPI DSI 1	22
I2C {CCI_0,CCI_1, SSC_2}	22
SPI {SSC_1}	22
SPI {SSC_UART_1, _2, _3}	22
TSIF – Transport Stream Interface	22
Other signals on Secondary High Speed Connector	22
<b>8 Analog Expansion Connectors</b>	<b>23</b>
16-pin Analog Connector	23
Earpiece	23
Microphones	23
Headset	23
<b>9 24 pin Audio Expansion</b>	<b>24</b>
Analog Microphones	24
Digital Microphones	24
Line Out	24

---

<b>10</b>	<b>Power management</b>	<b>25</b>
	DC Power Input	25
	Power Source Selection	25
	Power Consumption	25
	Power Sequencing	25
	Power Measurements	25
	DC-In measurement	25
	PMIC Power-In measurement (VPH_PWR measurement)	26
<b>11</b>	<b>Buttons and status LED's</b>	<b>27</b>
	Buttons	27
	Volume up	27
	Volume down	27
	Power Button	27
	Entering Fastboot	27
	Hard Reset	27
	Holding power and volume down buttons for 15 seconds will force a hard reset of the DragonBoard 820c.	27
	LEDs	27
	User LED 1-4	28
	Bluetooth status	28
	WiFi status	28
<b>12</b>	<b>Boot configuration</b>	<b>29</b>
<b>13</b>	<b>Mechanical specification</b>	<b>30</b>
	Additional interfaces	31
<b>14</b>	<b>License Agreement</b>	<b>32</b>
	EVALUATION BOARD LICENSE AGREEMENT	32
	WARRANTY	32
	INDEMNIFICATION	33
	RECYCLING	33

# Introduction

Acronyms and abbreviation definitions

Acronym / Abbreviation	Definition
BOM	Bill Of Materials
BT	Blue Tooth
CLK	Clock
CPU	Central Processing Unit
CS	Chip Select
CSI	Camera Serial Interface
DSI	Display Serial Interface
EMC	Electro-Magnetic Compatibility
EMI	Electro-Magnetic Interference
EN	ENable
ESD	Electro-Static Discharge
GND	GrouND
GPIO	General Purpose I/O
GPS	Global Positioning System
HDMI	High Definition Multimedia Interface
I2C	Inter-Integrated Circuit
I2S	Inter-IC Sound
INT	INTerrupt
ISP	Image Sensor Processor
LDO	Low Drop-Out
LRM	Linear Resonant Actuator
LTE	Long-Term Evolution
MDP	Mobile Display Port
MI2S	Mobile Inter-IC Sound
MIC	MICrophone
MIPI	Mobile Industry Processor Interface
MPP	Multi-Purpose Pin
NFC	Near Field Communication
PCB	Printed Circuit Board
PCIE	Peripheral Component Interconnect Express
PWM	Pulse-Width Modulation
RF	Radio Frequency
RX	Receive
SCL	Serial CLock
SDA	Serial DAta
SDC	Secure Digital Interface
SOM	System On Module
SPI	Serial Peripheral Interface
SSC	Snapdragon™ Sensor Core
TX	Transmit
UART	Universal Asynchronous Receiver/Transmitter
UIM	User Interface Module
USB	Universal Serial Bus
WLAN	Wireless Local Area Network

## Key features

The DragonBoard 820c ('820c') board is a 96Boards compliant community board based on Qualcomm® Snapdragon™ 820 processor.

The following table lists its key features:

Processor	<p>Qualcomm Snapdragon 820</p> <p>Quad-core Qualcomm® Kryo™ at up to 2.15GHz per core</p> <p>64-Bit capable</p> <p>Qualcomm® Adreno™ 530 624MHz GPU for PC-class graphics with support for advanced APIs, including OpenGL ES 3.1+, OpenCL, DirectX, and content security</p>
Memory/ Storage	<p>3GB LPDDR4 1866MHz</p> <p>32GB UFS 2.0</p> <p>SD 3.0 (UHS-I)</p>
Video	4K UltraHD@30fps video playback and capture with H.264 (AVC) and H.265 (HEVC)
Camera Support	Integrated Dual ISP with support for 3 image sensors up to 28MP
Audio	PCM/AAC+/MP3/WMA, ECNS, Audio+ post-processing (optional)
Connectivity	<p>WLAN 2x2 802.11 b/g/n/ac 2.4 and 5GHz with on-board dual band WLAN antennas</p> <p>Bluetooth v4.1 with on-board antenna</p> <p>GbE Ethernet connection</p> <p>One USB 2.0 micro B (device mode only)</p> <p>Two USB 3.0 (host mode only)</p> <p>GPS with On-board GPS antenna</p>
I/O Interfaces	<p>MINI PCIe</p> <p>One 40-pin Low Speed (LS) expansion connector</p> <ul style="list-style-type: none"> <li>• UARTx2, SPI, I2S, I2C x2, GPIO x12, DC power</li> </ul> <p>Primary 60-pin High Speed (HS) expansion connector</p> <ul style="list-style-type: none"> <li>• 4L-MIPI DSI, USB, I2C x2, 2L+4L-MIPI CSI, SPI</li> </ul> <p>Secondary 60-pin High Speed (HS) expansion connector</p> <ul style="list-style-type: none"> <li>• 4L-MIPI DSI, DC power, 1.8V supply, I2C, Camera Flash control, Display control, 2 x GPIO, Sensor core SPI, 3 x UART, I2C</li> </ul> <p>Audio support including:</p> <ul style="list-style-type: none"> <li>• Stereo Speaker and Mono microphone via 3.5mm headset jack</li> <li>• 24 pin audio expansion connector <ul style="list-style-type: none"> <li>• 3.3V supply, 2 x analog line in, 4 x analog line out, speaker amp control, 2 x digital microphone links supporting a total of 4 microphones</li> </ul> </li> </ul> <p><i>NOTE: Qualcomm Snapdragon, Kryo, Adreno and Hexagon are all products of Qualcomm Technologies, Inc.</i></p> <ul style="list-style-type: none"> <li>• 16 pin audio expansion connector <ul style="list-style-type: none"> <li>• stereo headset/line out, speaker and analog line in</li> </ul> </li> </ul>

	<p>Camera connector based upon 96boards camera interface addendum. 30 pin connector ZIF connector with 4L-CSI, DC power, 5V and 3.3V supply, camera control signals, I2C.</p> <p>The 820c board can be made compatible with Arduino compatible shield using an add-on mezzanine. Go to:</p> <p><a href="http://www.96boards.org/product/sensors-mezzanine/">http://www.96boards.org/product/sensors-mezzanine/</a></p> <p>For more information about compatible mezzanine cards</p>
External Storage	Micro SD card slot
User Interface	<p>Switches</p> <ul style="list-style-type: none"> <li>• Power/Reset</li> <li>• Volume Up</li> <li>• Volume down</li> </ul> <p>6 LED indicators</p> <ul style="list-style-type: none"> <li>• 4 - user controllable</li> <li>• 2 - for radios (BT and WLAN activity)</li> </ul>
Sensors	<p>6-axis IMU containing accelerometer and gyroscope</p> <p>3-axis magnetometer</p>
OS-support	Linux Debian
Power, Mechanical and Environmental	<p>Input voltage: +6.5V to +18V</p> <p>Dimensions: 100mm by 85mm meeting 96Boards™ Consumer Edition 'extended' dimensions specifications.</p> <p>Operating Temp: 0°C to +40°C</p> <p>RoHS and Reach compliant</p>

---

## Board overview

1.	(J11) Ethernet Connector
2.	(J1) Power Jack
3.	(J14) Camera Connector
4.	(J15) MINI PCIE Connector
5.	(J16) 3.5mm Headset Jack
6.	(J20) Secondary High Speed Connector
7.	(J21) 24 pin Audio Connector
8.	(J8) Low Speed Connector
9.	(DS10) Power up indicator
10.	GPS Antenna
11.	Shield Compartment containing APQ8096/LPDDR4, PM8996, WGR7640
12.	(S2) Power Button (S3-4) Vol+/Vol- Buttons
13.	(J5) microSD connector
14.	(J9) Primary High Speed Connector
15.	HDMI Connector
16.	(J4) Micro USB Type B Connector
17.	Bluetooth/WLAN LED's
18.	(J3) USB Host1 connector
19.	User LEDs 1-4
20.	(J2) USB Host2 connector
21.	WLAN/BT Antenna
22.	WLAN Antenna2
23.	(S1) Boot Switches



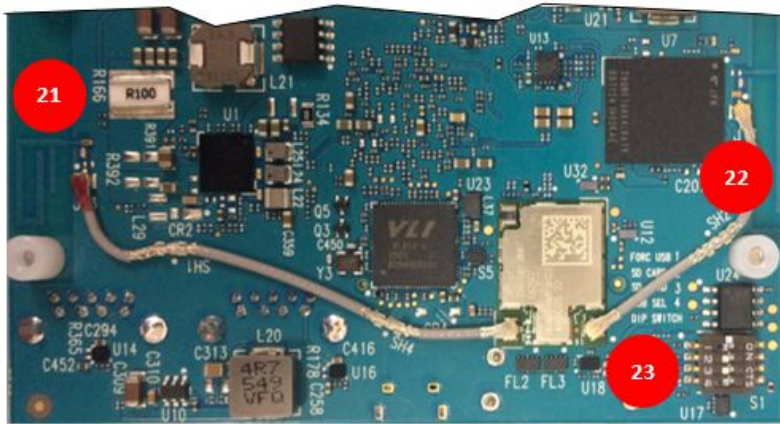
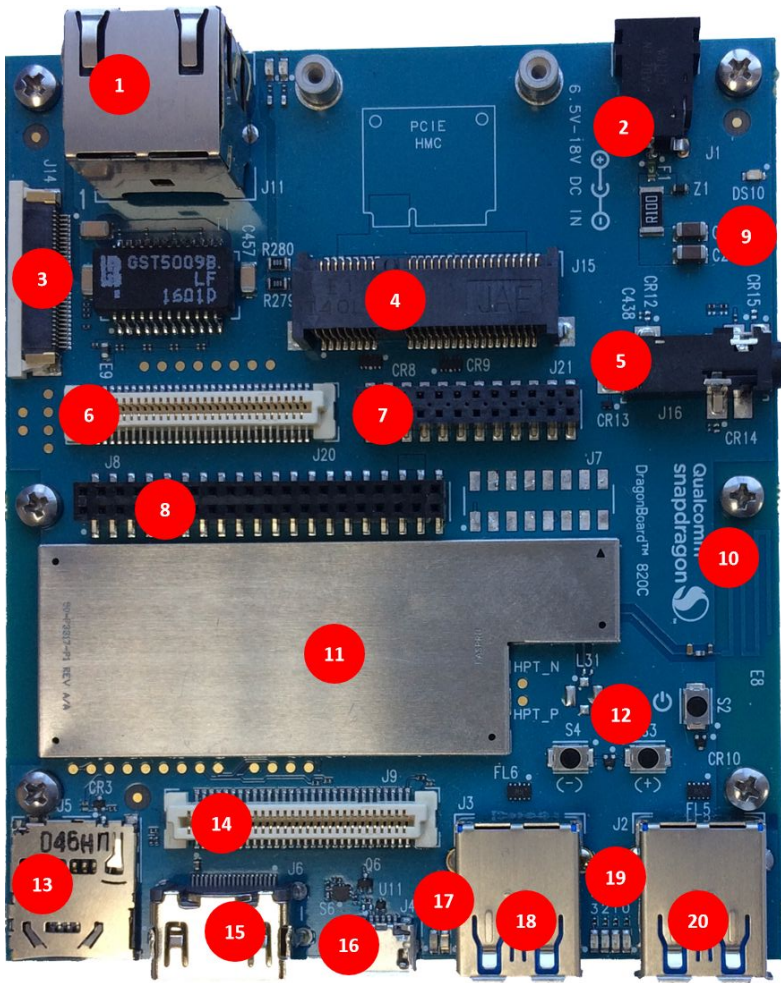

3

---

# What's in the Box

The box contains one DragonBoard 820c development board.

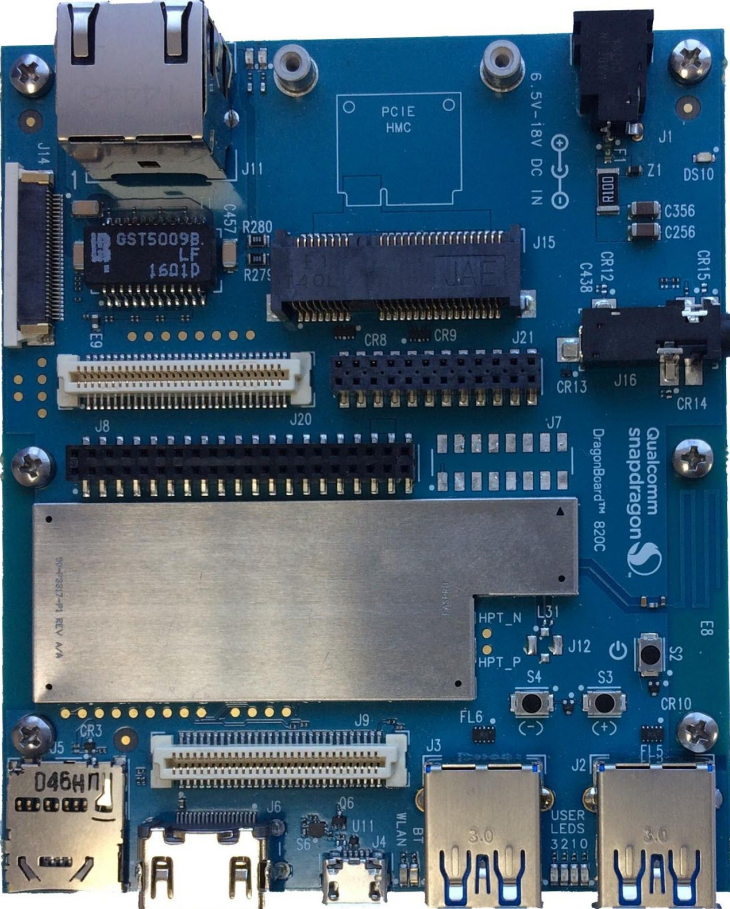

4

---

# Getting started

## Prerequisites

Before you power up your DragonBoard 820c for the first time you will need the following:

- DragonBoard 820c board
- A 96Boards compliant power supply (sold separately by Arrow) Input voltage range of 6.5-18V, recommended input current of 2A minimum.
- A HDMI or DVI LCD Monitor that supports a minimum resolution of 1080P/30Hz
- HDMI-HDMI cable or HDMI-DVI cable to connect the board to the Monitor
- A computer keyboard with USB interface
- A computer mouse with USB interface

## Starting the board for the first time

To start the board, follow these simple steps:

- step 1. Connect the HDMI cable to the 820c HDMI connector (marked J6) and to the LCD Monitor.
- step 2. Connect the mouse and keyboard to the 820C USB connectors marked J2 and. (It doesn't matter which order you connect them in. You can also connect via an external USB Hub.)
- step 3. Ensure that the boot switches S1 are set to '0000', all in Off position.**
- step 4. Connect the power supply to power connector J1.
- step 5. Plug the power supply into a power outlet.

The board will start the booting process, and you should see Linux boot up. The 'power up' blue LED 'DS10' should illuminate.

Please note that the first boot takes 3-4 minutes due to first time initialization. Subsequent boot times should be faster in the range of 1-2 minutes.

# DragonBoard Overview

## System Block diagram

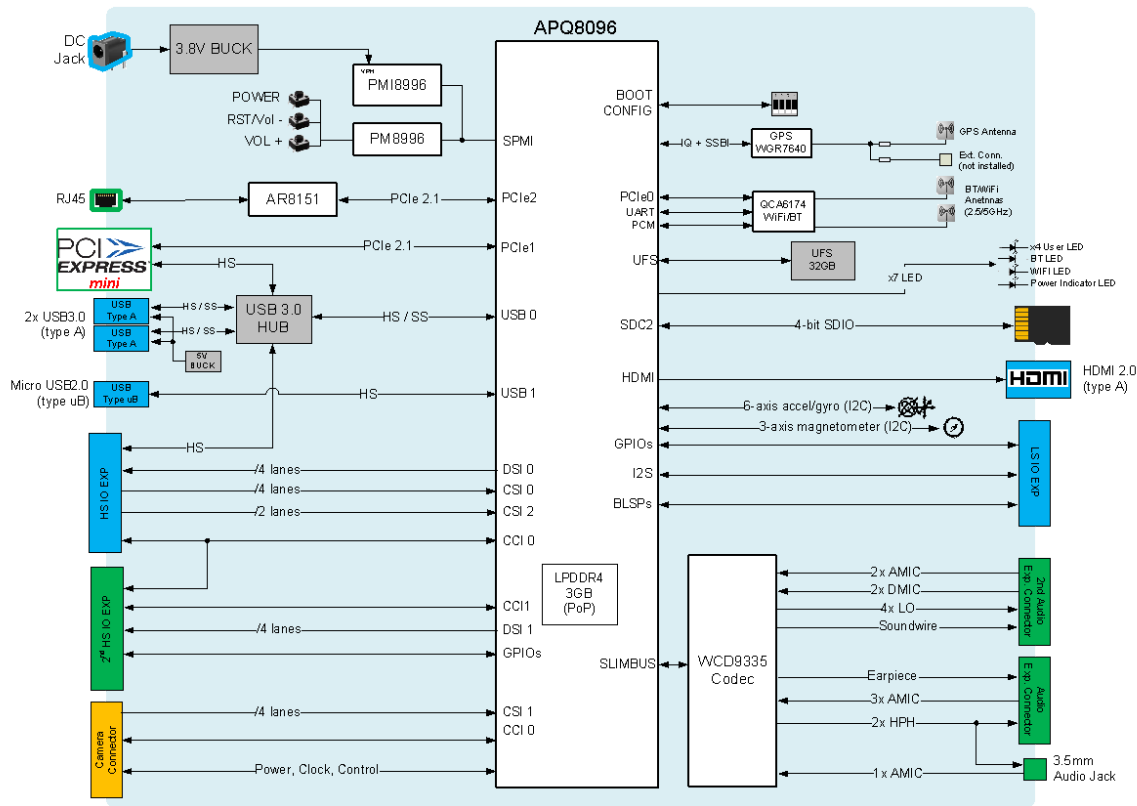

## Processor

The Snapdragon 820 (APQ8096) processor has a quad 64-bit Qualcomm® Kryo™ CPU , supporting LPDDR4 SDRAM interface, Hexagon 680 DSP, 28 MP camera input support, Adreno 530 GPU, 4K Ultra HD video encode/decode, gpsOneGen 8C with GLONASS, Bluetooth 4.1, OpenGL ES 3.1+, DirectX, OpenCL, Renderscript Compute, FlexRender support.

## Memory

The DragonBoard 820c uses a package on package (PoP) LPDDR4 RAM configuration and discrete UFS 2.0 flash memory

- The LPDDR4 interfaces directly to the APQ8096 built-in LPDDR controller. The maximum DDR clock is 1866 Mhz.
- The UFS flash memory interfaces with APQ8096 over a dedicated UFS/M-PHY bus supporting the UFS 2.0 specification.

## MicroSD

The 96Boards specification calls for a microSD socket to be present on the board.

The DragonBoard 820c μSD slot (J5) signals are routed directly to the APQ8096 SDC2 interface. The slot is a push-push type with a dedicated support for card detect signal (many μSD slots do not have a dedicated CD pins, they use DATA3 state as the card detected signal). The DragonBoard 820c uses APQ GPIO\_38 as the SD\_CARD\_DET\_N.

## WiFi/BT/RF

---

The 96Boards specifications calls for a WiFi (minimally 802.11g/n) and Bluetooth 4.1 (Bluetooth Low Energy)

The DragonBoard 820c uses Qualcomm QCA6174A module solution that integrates two wireless connectivity technologies into a single device, the interfaces are:

- WLAN compliant with IEEE 802.11 b/g/n/ac specifications, exceeding 96Boards minimal requirements for WiFi.
- Bluetooth compliant with the BT specifications version 4.1 (BR/EDT + BLE), meeting the 96Boards requirements for BT

## Display Interface

### HDMI

The 96Boards specification calls for an HDMI port to be on the board. The DragonBoard 820c provides native support for an HDMI interface. It supports a resolution up to 4K Ultra HD resolution at 60Hz.

### MIPI-DSI

The 96Boards specification calls for a MIPI-DSI implementation via the High Speed Expansion Connector.

The 820c implements a four-lane MIPI\_DSI on the primary high speed connector interface which meets the 96boards MIPI-DSI high speed connector requirement. An additional four-lane MIPI\_DSI bus is implemented on the secondary high speed connector. More information about this implementation can be found in [chapter 7 High speed expansion connector](#).

## Camera Interfaces

The 96Boards specification calls for two camera interfaces.

The DragonBoard 820c implements three camera interfaces.

- 4 lane CSI camera on camera connector J14
- 4 lane CSI camera on primary high speed connector J9
- 2 lane CSI camera on primary high speed connector J9

The DragonBoard 820c includes an on-board 4-lane MIPI-CSI camera bus, routed to a 30 pin ZIF connector.

More information about this implementation can be found in [chapter 6 High speed expansion connector](#).

## USB Ports

### USB-Host ports

The 96Boards specification calls for three USB host ports.

The DragonBoard 820c supports 3 USB Host ports as follows.

Port 1 of the USB HUB is routed to J2, a Type 'A' USB Host 3.0 (Superspeed) connector. A current limited controller (U14) sets the Power Current limit to 1.0A. This port is named HOST1 in the board schematic.

Port 2 of the USB HUB is routed to J3, a Type 'A' USB Host 3.0 (Superspeed) connector. A current limited controller (U16) sets the Power Current limit to 1.0A. This port is named HOST2 in the board schematic.

Port 3 of the USB HUB is routed to the High Speed Expansion connector. No current limited controller is implemented on the board for this channel.

### USB-Device port

The 96Boards specification calls for a USB port to be implemented as an OTG port or a device port.

The DragonBoard 820c implements a USB device port. The port is located at J4, a MicroUSB type B. If an application requires the use of the device port, USB\_HUB\_SEL switch (S1-4) shall be set to '0' which is the default setting. Setting USB\_SEL switch S1-4 to 'ON' will put the 820C into Emergency Download mode (EDL) which will render the device

---

unusable for all other functionality.

## Audio

The 96Boards specifications calls for a minimum of single channel audio through two interfaces, BT and HDMI/MHL/DisplayPort

The DragonBoard 820c meets this requirement with HDMI support and has additional audio channels, including support for headset jack. More information about these additional channels can be found in sections [7](#) and [8](#).

Note that MHL is not supported.

## BT Audio

The BT 4.1 implementation on the DragonBoard 820c is via a MAC in the APQ8096 and an external modem, contained in the WIFI/BT module.

## HDMI Audio

HDMI audio is carried over the HDMI signals to the HDMI connector (J6).

## Input DC-power

The 96Boards specification calls for power to be provided to the board in one of the following ways:

- 8V to 18V input voltage power supplied from a dedicated DC jack
- 8V to 18V input voltage power supplied from the SYS\_DCIN pins on the Low Speed Expansion Connector
- A USB Type C port at 5V

Please see [section 9](#) for detailed information on DragonBoard 820c implementation of DC Power. Note that the DragonBoard 820c does not support USB Type C.

## Measurements

The 96Boards specification calls for support for measuring power consumptions of the board.

Please see [the power measurement](#) section for detailed information on DragonBoard 820c power measurement implementation.

## Buttons

The 96Boards specification calls for the presence of two buttons, a Power on/sleep button and a Reset button.

This board meets these requirements. Please see [section 10](#) for detailed information on the buttons of the DragonBoard 820c.

## UART

The 96Boards specification calls for support for one SoC UART and an optional second UART both to be routed to the Low Speed Expansion Connector.

The DragonBoard 820c routes 2 UARTs to the low speed connector and additionally routes 3 SSC UART TX/RX lines to the secondary high speed connector J20.

## System and user LEDs

The 96Boards specifications calls for six LEDs to be implemented on the board. The specification defines the LEDs color and mechanical location on the board.

### Two activity LEDs:

- WiFi activity LED – DragonBoard 820c drives this Yellow LED via MPP\_2, an IO from the PMIC.

- 
- BT activity LED – DragonBoard 820c drives this Blue LED via MPP\_4 an IO from the PMIC.

#### **Four User-LEDs:**

The four user LEDs are surface mount Green in 0603 size located next to the two USB type A connector and labeled 'USER LED3 2 1 0'. The DragonBoard 820c drives three LEDs from the red, green and blue LED drive from power management IC PMI8996. The fourth User LEDs is driven by the PMI8996 via PM MPP2.

#### **Power indicator LED:**

A blue LED is included to indicate the presence of input power to the DragonBoard 820c.

## **Expansion Connector**

The 96Boards specification calls for two Expansion Connectors, a Low Speed and a High Speed.

The DragonBoard 820c meets this requirement for low speed and exceeds it by having two high speed connectors, please review section 6.0 for detailed information regarding the Low Speed Expansion Connector and section 7.0 for detailed information regarding the High Speed Expansion Connectors.

## **Additional Functionality**

The 96Boards specifications allows for additional functionality provided that all mandatory functionality is available and there is no impact on the physical footprint specifications including height and do not prevent the use of the 96Boards CE low speed and high speed expansion facilities

The DragonBoard 820c implements additional functions, which are listed in the following sub-chapters.

### **GPS**

The GPS implementation is based on Qualcomm WGR7640 GNSS RF receiver (U5) supporting GPS, GLONASS and COMPASS. The APQ8096 communicates directly with the WGR7640.

### **Ethernet Connector**

Gigabit Ethernet is supported by Qualcomm AR8151 controller and uses an RJ45 as the physical interface.

### **Mini PCIE connector**

The DragonBoard 820c includes a mini PCIE (PCI express) connector. This enables integration of HW peripherals which are compliant to the PCIE mini specification.

### **Inertial Sensors**

The DragonBoard 820c includes the following inertial sensors

- 6-axis accelerometer/gyroscope: ST Micro LSM6DS3
- 3-axis magnetometer: ST Micro LIS3MDL

## **6**

## Low speed Expansion connector

The following tables show the Low Speed Expansion Connector pin out:

PIN	96Boards Signals	820c Signals	Note
1	GND	GND	
3	UART0_CTS	UART0_CTS_N (APQ GPIO_51)	
5	UART0_TxD	UART0_TX (APQ GPIO_49)	
7	UART0_RxD	UART0_RX (APQ GPIO_50)	
9	UART0_RTS	UART0_RTS_N (APQ GPIO_52)	
11	UART1_TxD	UART1_TX (APQ GPIO_4)	
13	UART1_RxD	UART1_RX (APQ GPIO_5)	
15	I2C0_SCL	I2C0_SCL (APQ GPIO_48)	
17	I2C0_SDA	I2C0_SDA (APQ GPIO_47)	
19	I2C1_SCL	I2C1_SCL (APQ GPIO_7)	
21	I2C1_SDA	I2C1_SDA (APQ GPIO_6)	
23	GPIO-A	LS_EXP_GPIO_A (APQ GPIO_80)	
25	GPIO-C	LS_EXP_GPIO_C (APQ GPIO_124)	
27	GPIO-E	LS_EXP_GPIO_E (APQ GPIO_62)	
29	GPIO-G	LS_EXP_GPIO_G (APQ GPIO_10)	
31	GPIO-I	LS_EXP_GPIO_I (APQ GPIO_25)	
33	GPIO-K	LS_EXP_GPIO_K (APQ GPIO_23)	
35	+1V8	VREG_S4_1P8	
37	+5V	VREG_5P0	
39	GND	GND	

PIN	96Boards Signals	820c Signals	Note
2	GND	GND	
4	PWR_BTN_N	PHONE_ON_N	
6	RST_BTN_N	PM_RESIN_N	
8	SPI0_SCLK	SPI0_CLK (APQ GPIO_3)	
10	SPI0_DIN	SPI0_MISO (APQ GPIO_1)	
12	SPI0_CS	SPI0_CS_N (APQ GPIO_2)	
14	SPI0_DOUT	SPI0_MOSI (APQ GPIO_0)	
16	PCM_FS	PCM_FS (APQ GPIO_59)	
18	PCM_CLK	PCM_CLK (APQ GPIO_58)	
20	PCM_DO	PCM_DO (APQ GPIO_60)	
22	PCM_DI	PCM_DI (APQ GPIO61)	
24	GPIO-B	GPIO_B (APQ GPIO_29)	
26	GPIO-D	GPIO_D (APQ GPIO_24)	
28	GPIO-F	GPIO_F (PM_GPIO_5)	<b>Used GPIO from PMIC</b>
30	GPIO-H	GPIO_H (APQ GPIO_8)	
32	GPIO-J	GPIO_J (APQ GPIO_26)	
34	GPIO-L	GPIO_L (APQ GPIO_133)	
36	SYS_DCIN	SYS_DCIN	



38	SYC_DCIN	SYS_DCIN	
40	GND	GND	

## UART {0/1}

The 96Boards specifications calls for a 4-wire UART implementation, UART0 and an optional second 2-wire UART, UART1 on the Low Speed Expansion Connector.

The DragonBoard 820c implements UART0 as a 4-wire UART that connects directly to the APQ8096 SoC. These signals are driven at 1.8V.

The DragonBoard820c implements UART1 as a 2-wire UART that connects directly to the APQ8096 SoC. These signals are driven at 1.8V.

## I2C {0/1}

The 96Boards specification calls for two I2C interfaces to be implemented on the Low Speed Expansion Connector.

The DragonBoard 820c implements both interfaces, I2C0 and I2C1 that connects directly to the APQ8096 SoC. A 2.2K resistor is provided as pull-up for each of the I2C lines per the I2C specifications, these pull-ups are connected to the 1.8V voltage rail.

## GPIO {A-L}

The 96Boards specifications calls for 12 GPIO lines to be implemented on the Low Speed Expansion Connector. Some of these GPIOs may support alternate functions for DSI/CSI control

The DragonBoard 820c implements this requirement. 11 GPIOs are routed to the APQ8096 SoC and one GPIO is connected to the on-board PMIC. All are 1.8V signals. Reference the connector pinout table for details regarding GPIO assignments

- Note: GPIO C - Connects to GPIO\_125 of APQ8096 SoC, can serves as TS\_INT0 supporting the 96Boards requirements to create a wake-up event for the SoC.

## SPI 0

The 96Boards specification calls for one SPI bus master to be provided on the Low Speed Expansion Connector.

The DragonBoard 820c implements a full SPI master with 4 wires, CLK, CS, MOSI and MISO all connect directly to the APQ8096 SoC. These signals are driven at 1.8V.

## PCM/I2S

The 96Boards specification calls for one PCM/I2S bus to be provided on the Low Speed Expansion Connector. The CLK, FS and DO signals are required while the DI is optional.

The DragonBoard 820c implements a PCM/I2S with 4 wires, CLK, FS, D0 and DI. The I2S signals are connected directly to the APQ8096 SoC. These signals are driven at 1.8V.

## Power and Reset

The 96Boards specification calls for a signal on the Low Speed Expansion Connector that can power on/off the board and a signal that serves as a board reset signal.

The DragonBoard820c routes the PWR\_BTN\_N (named PHONE\_ON\_N on 820c schematic) signal to the KYPDPWR\_N pin of the PMI8996 PMIC. This signal is driven by S2 as well, the on-board power on push-button switch. Please note that the push button only provides an On/Sleep function and not OFF functionality.

A mezzanine implementation of this signals should not drive it with any voltage, the only allowed operation is to force it to

---

GND to start the board from a sleep mode. A board shutdown will occur when this signal is held to ground for more than 15 seconds.

The DragonBoard 820c routes the RST\_BTN\_N (named PM\_RESIN\_N on 820c schematic) signal to the RESIN\_N pin of the PMI8996 PMIC. This signal is driven by S4, the on-board reset switch. This signal is a dual purpose, any press lasting less than 10 seconds serves as Volume Down or Zoom out, a press longer than 10 seconds will reset the board.

## Power Supplies

The 96Boards specification calls for three power rails to be present on the Low Speed Expansion Connector:

- +1.8V : Max of 100mA
- +5V : Able to provide a minimum of 5W of power (1A).
- SYS\_DCIN : 9-18V input with enough current to support all the board functions or the output DCIN from on-board DC Connector able to provide a minimum of 7W of power.

The DragonBoard 820c supports these requirements as follows:

+1.8V : Driven by PMIC LDO VREG\_S4, which can provide 100mA.

+5V : Driven by the 5A 5.0V DC to DC converter (U10). This buck switcher powers both USB limit current devices (each at 1.0A max). The remaining capacity provides a max current of 3A to the Low Speed Expansion Connector, for a total of 8.2W which meets the 96Boards requirements.

SYS\_DCIN: Can serve as the board's main power source or can receive power from the board. It supports a minimum of 7W.

## 7

# High speed expansion connectors

## Primary high speed expansion connector

The following table shows the High Speed Expansion Connector pin out:

PIN	96Boards Signals	820c Signals	Note	
1	SD_DAT0/SPI1_DOUT	SPI1_MOSI (APQ GPIO_85)	<b><i>This is a SPI implementation. not an SD interface</i></b>	
3	SD_DAT1	N.C.		
5	SD_DAT2	N.C.		
7	SD_DAT3/SPI1_CS	SPI1_CS_N (APQ GPIO_87)		
9	SD_SCLK/SPI1_SCLK	SPI1_CLK (APQ GPIO_88)		
11	SD_CMD/SPI1_DIN	SPI1_MISO (APQ GPIO_86)		
13	GND	GND		
15	CLK0/CS10_MCLK	CS10_MCLK (APQ GPIO_13)		
17	CLK1/CS11_MCLK	CS11_MCLK (APQ GPIO_15)		
19	GND	GND		
21	DSI_CLK+	MIPI_DSIO_CLK_P_EXP_CONN		
23	DSI_CLK-	MIPI_DSIO_CLK_M_EXP_CONN		
25	GND	GND		
27	DSI_D0+	MIPI_DSIO_DATA0_P_EXP_CONN		
29	DSI_D0-	MIPI_DSIO_DATA0_M_EXP_CONN		
31	GND	GND		
33	DSI_D1+	MIPI_DSIO_DATA1_P_EXP_CONN		
35	DSI_D1-	MIPI_DSIO_DATA1_M_EXP_CONN		
37	GND	GND		
39	DSI_D2+	MIPI_DSIO_DATA2_P_EXP_CONN		
41	DSI_D2-	MIPI_DSIO_DATA2_M_EXP_CONN		
43	GND	GND		
45	DSI_D3+	MIPI_DSIO_DATA3_P_EXP_CONN		
47	DSI_D3-	MIPI_DSIO_DATA3_M_EXP_CONN		
49	GND	GND		
51	USB_D+	USB_HS_D_P_EXP		<b><i>No HSIC implementation</i></b>
53	USB_D-	USB_HS_D_M_EXP		
55	GND	GND		
57	HSIC_STR	N.C.		
59	HSIC_DATA	N.C.		

PIN	96Boards Signals	820c Signals	Note
2	CS10_C+	MIPI_CSIO_CLK_P	
4	CS10_C-	MIPI_CSIO_CLK_M	
6	GND	GND	
8	CS10_D0+	MIPI_CSIO_DATA0_P	
10	CS10_D0-	MIPI_CSIO_DATA0_M	
12	GND	GND	
14	CS10_D1+	MIPI_CSIO_DATA1_P	
16	CCSIO_D1-	MIPI_CSIO_DATA1_M	
18	GND	GND	
20	CS10_D2+	MIPI_CSIO_DATA2_P	
22	CS10_D2-	MIPI_CSIO_DATA2_M	
24	GND	GND	

26	CSI0_D3+	MIPI_CSI0_DATA3_P
28	CSI0_D3-	MIPI_CSI0_DATA3_M
30	GND	GND
32	I2C2_SCL	I2C2_SCL (APQ GPIO_18)
34	I2C2_SDA	I2C2_SDA (APQ GPIO_17)
36	I2C3_SDA	I2C3_SCL (APQ GPIO_56)
38	I2C3_SDA	I2C3_SDA (APQ GPIO_55)
40	GND	GND
42	CSI1_D0+	MIPI_CSI2_DATA0_P
44	CSI1_D0-	MIPI_CSI2_DATA0_M
46	GND	GND
48	CSI1_D1+	MIPI_CSI2_DATA1_P
50	CSI1_D1-	MIPI_CSI2_DATA1_M
52	GND	GND
54	CSI1_C+	MIPI_CSI2_CLK_P
56	CSI1_C-	MIPI_CSI2_CLK_M
58	GND	GND
60	RESERVED	VREG_S4_1P8

## MIPI DSI 0

The 96Boards specification calls for a MIPI-DSI to be present on the High Speed Expansion Connector. A minimum of one lane is required and up to four lanes can be accommodated on the connector.

The DragonBoard 820c implementation supports a full four lane MIPI-DSI interface that is routed to the Primary High Speed Expansion Connector.

## MIPI CSI {0/1}

The 96Boards specification calls for two MIPI-CSI interfaces to be present on the High Speed Expansion Connector. Both interfaces are optional. CSI0 interface can be up to four lanes while CSI1 is up to two lanes.

The current DragonBoard 820c implementation supports a full four lane MIPI-CSI interface on CSI0 and two lanes of MIPI-CSI on CSI2. All MIPI-CSI signals are routed directly to/from the APQ8096.

## I2C {2/3}

The 96Boards specification calls for two I2C interfaces to be present on the High Speed Expansion Connector. Both interfaces are optional unless a MIPI-CSI interface has been implemented. Then an I2C interface shall be implemented.

The current DragonBoard820c implementation supports two MIPI-CSI interfaces and therefore must support two I2C interfaces.

For MIPI-CSI0 the companion I2C2 is routed directly from the APQ8096. For MIPI-CSI2, the companion I2C is I2C3.

## HSIC

The 96Boards specification calls for an optional MIPI-HSIC interface to be present on the High Speed Expansion Connector.

The DragonBoard 820c implementation doesn't support this optional requirement.

## Reserved

The 96Boards specification calls for a 100K pull-up to 1.8V to be connected to pin 60 of the High Speed Expansion Connector.

The DragonBoard 820c utilizes a 100K pull-up (R147) on pin 60.

## SD/SPI

The 96Boards specification calls for an SD interface or a SPI port to be part of the High Speed Expansion Connector.

The DragonBoard 820c implements a full SPI master with 4 wires (96Boards SPI Configuration), CLK, CS, MOSI and MISO all connect directly to the APQ8096 SoC. These signals are driven at 1.8V.

## Clocks

The 96Boards specification calls for one or two programmable clock interfaces to be provided on the High Speed Expansion Connector. These clocks may have a secondary function of being CSI0\_MCLK and CSI1\_MCLK. If these clocks can't be supported by the SoC than an alternative GPIO or No-Connect is allowed by the specifications.

The DragonBoard 820c implements two CSI clocks, CAM\_MCLK0 via APQ GPIO\_13 for CSI0 and CAM\_MCLK2 via APQ GPIO\_15 for CSI1. These signals are driven at 1.8V.

## USB

The 96Boards specification calls for a USB Data line interface to be present on the High Speed Expansion Connector.

The DragonBoard 820c implements this requirement by routing USB channel 3 from the USB HUB to the High Speed Expansion Connector.

## Secondary High Speed Connector

Given the extensive I/O available on the APQ8096, a second high speed connector has been added to support additional interfaces for development and integration.

Currently, the SW supporting these features is pre-commercial and many features are not implemented. Refer to the notes section in the table regarding SW support.

While there are functions assigned for primary usages such as I2C bus, SPI bus, TSIF, etc., most pins can be repurposed as GPIOs if needed and their GPIO # assignments are included for reference. The following table shows the Secondary High Speed Expansion Connector pin out:

PIN	820c Signals	Note
1	FLASH_STROBE_TRIGGER (APQ GPIO_22)	Configured for GPIO use only
3	MI2S_MCLK (APQ GPIO_57)	Configured for GPIO use only
5	FLASH_STROBE_EN (APQ GPIO_21)	Configured for GPIO use only
7	SSC_SPI1_CS_N (APQ SSC8)	Currently not configured in SW
9	SSC_SPI1_CLK (APQ SSC9)	Currently not configured in SW
11	BL1_EN (PMGPIO_6)	
13	GND	
15	SSC_SPI_1_MOSI (APQ SSC10)	Currently not configured in SW
17	SSC_SPI_1_MISO (APQ SSC11)	Currently not configured in SW
19	GND	
21	MIPI_DSI1_CLK_P_EXP_CONN	
23	MIPI_DSI1_CLK_M_EXP_CONN	
25	GND	
27	MIPI_DSI1_DATA0_P	
29	MIPI_DSI1_DATA0_M	
31	GND	
33	MIPI_DSI1_DATA1_P	
35	MIPI_DSI1_DATA1_M	
37	GND	
39	MIPI_DSI1_DATA2	

41	MIPI_DSI1_DATA2	
43	GND	
45	MIPI_DSI1_DATA3_P	
47	MIPI_DSI1_DATA3_M	
49	GND	
51	LCD1_RESET_N (APQ-GPIO101)	Currently not configured in SW
53	BL1_PWM (PM-GPIO4)	
55	MDP_VSYNC_S (APQ-GPIO11)	Currently not configured in SW
57	DC_IN	500mA max input on these pins
59	DC_IN	

PIN	820c Signals	Note
2	APQ-GPIO121	Currently not configured in SW
4	APQ-GPIO30	Configured as Cam/Stdby
6	GND	
8	SSC_UART_3_TX (APQ SSC6)	Currently not configured in SW
10	SSC_UART_3_RX (APQ SSC7)	Currently not configured in SW
12	GND	
14	SSC_UART_1_TX (APQ SSC12)	Currently not configured in SW
16	SSC_UART_1_RX (APQ SSC13)	Currently not configured in SW
18	GND	
20	SSC_UART_2_TX (APQ SSC14)	Currently not configured in SW
22	SSC_UART_2_RX (APQ SSC15)	Currently not configured in SW
24	GND	
26	SSC_I2C_2_SDA (APQ SSC4)	Currently not configured in SW
28	SSC_I2C_2_SCL (APQ SSC5)	Currently not configured in SW
30	GND	
32	CCI_I2C_SCL0 (APQ GPIO_18)	
34	CCI_I2C_SDA0 (APQ GPIO_17)	
36	CCI_I2C_SCL1 (APQ GPIO_20)	
38	CCI_I2C_SDA1 (APQ GPIO_19)	
40	GND	
42	APQ GPIO_89)	
44	APQ GPIO_91	
46	APQ GPIO_90	
48	APQ GPIO_39	
50	GND	
52	APQ GPIO_93	
54	(APQ GPIO_95	
56	APQ GPIO_94	
58	APQ GPIO_96	
60	VREG_S4A_1P8	

### Feature information

Please refer to table notes column regarding which features are currently supported in SW.

---

## MIPI DSI 1

The secondary high speed connector supports a 4-lane MIPI-DSI bus.

Additional signals on the secondary high speed connector which can be used for display integration include:

- BL1\_EN (APQ-GPIO6) for backlight control.
- LCD1\_RESET\_N (APQ-GPIO101). Display control line.
- BL1\_PWM (PM-GPIO4). For backlight level control.
- MDP\_VSYNC\_S(APQ-GPIO11). Display timing control

These signals can also be used as generic GPIOs

## I2C {CCI\_0, CCI\_1, SSC\_2}

The secondary high speed connector supports three I2C busses.

- CCI\_I2C\_0
- CCI\_I2C\_1
- SSC\_I2C\_2

These busses can also be used as generic GPIOs

## SPI {SSC\_1}

The secondary high speed connector supports one SPI bus- SSC\_SPI\_1.

This bus can also be used as generic GPIOs

## SPI {SSC\_UART\_1, \_2, \_3}

The secondary high speed connector supports three UART busses- SSC\_UART\_1, \_2 and \_3

These busses can also be used as generic GPIOs.

## TSIF – Transport Stream Interface

XXXXXX

## Other signals on Secondary High Speed Connector

Other signals include

- 1.8V supply
- DC\_IN 6.5V to 18V with up to 500mA maximum per pin on two pins
- APQ-GPIO122
- APQ-GPIO30
- FLASH\_STROBE\_TRIGGER (APQ-GPIO22)
- MI2S\_MCLK (APQ-GPIO57)
- FLASH\_STROBE\_EN (APQ-GPIO21)

---

# Analog Expansion Connectors

## 16-pin Analog Connector

Unless otherwise noted, these signals interface to the WCD9335 codec (U3).

PIN	Function	Connect to	Note
1	CDC_EAR_M		
2	CDC_EAR_P		
3	VPH_PWR	3.8V from U20 buck switcher	
4	GND		
5	CDC_IN1_M		
6	CDC_IN4_P		Mic 4 can be used for ANC headset
7	CDC_IN1_P		
8	CDC_HPH_R		
9	HPH_REF		
10	CDC_HPH_L		
11	MBHC_HS_DET_L		Mechanical insertion detection
12	MIC_BIAS2		
13	CDC_IN4_M		Mic 4 can be used for ANC headset
14	CDC_IN3_M		Mic 3 can be used for ANC headset
15	N.C.		
16	CDC_IN3_P		Mic 3 can be used for ANC headset

### Earpiece

The earpiece signals are routed from the WCD9335 codec, the two signals are:

- CDC\_EAR\_M
- CDC\_EAR\_P

### Microphones

The 3 analog microphones are connected to the WCD9335 codec, the three mics are:

- MIC1
- MIC3 Can be used as part of an active noise canceling (ANC) system
- MIC4 Can be used as part of an active noise canceling (ANC) system
- MIC\_BIAS2 Ground reference

### Headset

The headset signals are rounded from the WCD9335 codec, one signal is routed from the connector to the CODEC, the singles are:

- CDC\_HPH\_R - Headphone PA right channel output
- CDC\_HPH\_L - Headphone PA left channel output
- HPH\_REF - Headphone PA ground sensing
- MBHC\_HS\_DET\_L- Headset detection



---

## 24 pin Audio Expansion

Unless otherwise noted, these signals interface to the WCD9335 codec (U3).

PIN	Function	Connect to	Note
1	CDC_IN5_M		
2	CDC_IN6_M		
3	CDC_IN5_P		
4	CDC_IN6_P		
5	MIC_BIAS3		
6	MIC_BIAS1		
7	GND		
8	SPKR_AMP_EN1	PMI8996 (U1)	
9	CDC_SWR_CLK		
10	CDC_SWR_DATA		
11	SPKR_AMP_EN2	PMI8996 (U1)	
12	GND		
13	CDC_DMIC_CLK1		
14	CDC_DMIC_CLK2		
15	CDC_DMIC_DATA1		
16	CDC_DMIC_DATA2		
17	CDC_LINE_OUT2_M		
18	CDC_LINE_OUT2_P		
19	CDC_LINE_OUT1_M		
20	CDC_LINE_OUT1_P		
21	CDC_LINE_REF		
22	VREG_3P3	3.3V from U20 buck switcher	
23	CDC_LINE_OUT4		
24	CDC_LINE_OUT3		

### Analog Microphones

The 24 pin audio expansion connector supports 2 additional analog microphone inputs:

- MIC5
- MIC6
- MIC\_BIAS1, \_BIAS3: Ground reference

### Digital Microphones

The 24 pin audio expansion connector supports 2 additional analog microphone inputs:

- DMIC\_1
- DMIC\_2

### Line Out

The 24 pin audio expansion connector supports 4 line outputs:

Line\_Out1, Line\_Out2: Differential driven Line\_Out3, Line\_out4: Single ended with CDC\_Line\_Ref to use as a reference ground.

- Audio Amplifier interface. The 24 pin audio expansion connector supports the following interface and control of audio amplifiers: Soundwire (CDC\_SWR\_CLK, SWR\_DATA): Used and audio interface to Qualcomm WSA8810 or 8815 speaker amplifiers.
- Amplifier control via SPKR\_AMP\_EN1, \_EN2



---

## Power management

The 96Boards specification defines how power arrives to the board and few supplies that the board needs to provide. The on board power requirement for each 96Boards implementation depends on the SoC and the set of peripherals that are specific to that implementation.

The DragonBoard 820c uses three buck regulators, U20, U10 and U21. U20 takes the power in to the board and generates 3.8V at 6A. This voltage serves as the power in voltage to the on-board PMI8996 IC. U10 takes the power in to the board and generates 5V at 5A. This voltage feeds the USB HOST power limit switches, provides power to the Low Speed Expansion port and other HW peripheral interfaces. U21 takes the power in to the board and generates 3.3V at 5A. 3.3V is used to power HW peripherals as well as to expansion connectors.

### DC Power Input

The 96Boards specification calls for a power to be provided to the board in one of the following ways:

- An 8V to 18V power from a dedicated DC jack.
  - The DragonBoard 820c supports this requirement through the use of J1, 'SYS\_DCIN' power connector.  
**Please note:** the SYS\_DCIN can be as low as 6.5V on the DragonBoard820c.
- Note that the DragonBoard 820c operates from a ~24W supply such as a 12V/2A supply. An 8V to 18V power from the SYS\_DCIN pins on the Low Speed Expansion Connector.  
**Please note:** the SYS\_DCIN can be as low as 6.5V on the DragonBoard820c.  
The DragonBoard 820c supports incoming power through this connector.
- A USB Type C port at 5V.  
**Please note: The DragonBoard 820c does not implement a USB Type C port and therefore cannot be powered over USB.**

### Power Source Selection

Following the information in section 9.1, the DragonBoard 820c has only two sources for board incoming power. The 96Boards specification calls for only one power source to be applied to the board at any given time. Following this requirement, **the user of the DragonBoard 820c should never apply power to the board from J1 and the Low Speed Expansion connector at the same time.** There is no active or passive mechanism on the DragonBoard 820c to prioritize one source over the other.

### Power Consumption

TBD

### Power Sequencing

Upon applying power to the DragonBoard 820c (either one of the two sources), both buck regulators will be enabled and will start regulating their target voltages. When the output of U20 is on, it will power the on-board PMIC, the PMI8996. PMI8996 generates VPH\_PWR which supplies the PM8996. The sequencing of all power rails is set within the PMIC configuration scheme during the production of this part. The user has no access to alter, modify or change the PMIC power up sequencing.

### Power Measurements

The 96Boards specification calls for a minimum of one current sense resistor to be placed on the board permitting a basic power measurement functions.

The DragonBoard 820c implements two different power measurements.

#### DC-In measurement

A 0.01ohm resistor R167 is placed inline to the SYS\_DCIN power line coming from J1 (please note that this power in measurement only works for SYS\_DCIN from J1, it will not measure SYS\_DCIN applied from the Low Speed Expansion

---

Connector). The two sides of this resistor are connector to pins J10-1 and J10-2. Placing a probe over these jumper pins will provide a voltage measurement of the voltage drop across the resistor. Dividing this measurement by 0.01 will give you the amount of the current flowing into the board.

### **PMIC Power-In measurement (VPH\_PWR measurement)**

A 0.01ohm resistor R166 is placed inline to the SYS\_PWR on the 3.8V supply on the output of U20. The two sides of this resistor are connector to pins J22-1 and J22-2. Placing a probe over these jumper pins will provide a voltage measurement of the voltage drop across the resistor. Dividing this measurement by 0.01 will give you the amount of the current flowing into the board.

## **11**

---

## Buttons and status LED's

### Buttons

#### Volume up

The Volume UP button (S3) is used to control the audio volume of the DragonBoard 820c.

#### Volume down

The Volume Down button (S4) is used to control the audio volume of the DragonBoard 820c.

#### Power Button

The push-button S2 serves as the power-on/off/sleep button. Upon applying power to the board, the boot process will start. Once the board is powered on and booted up:

##### Sleep/suspend

- You can put the device to sleep by pressing this button momentarily.
- You can wake the device from sleep by pressing this button momentarily.

##### Power Off/On

###### Option 1: Long press/hold

- While the device is awake, pressing and holding the power button S2 for longer than 15 seconds will result in the device powering off.
- Once powered off, pressing and holding the power button S2 for longer than 15 seconds will result in the device powering on.

###### Option 2: Short press/hold

- While the device is awake, pressing and holding the power button S2 for ~2-3 seconds will result in the user interface displaying the 'power off' notifier:

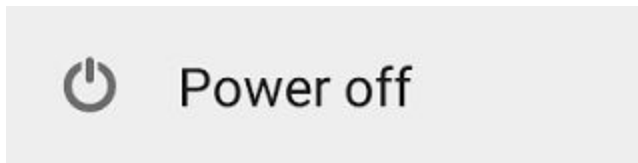

- Using a mouse, clicking on this notifier will cause the 820c to power off.
- Once powered off, pressing and holding the power button S2 for longer than 2-3 seconds will result in the device powering on.

#### Entering Fastboot

Holding down power and volume down buttons at power up of the DragonBoard 820c will force the device to enter fastboot mode.

#### Hard Reset

**Holding power and volume down buttons for 15 seconds will force a hard reset of the DragonBoard 820c.**

#### LEDs

There are two status LEDs and four User LEDs on the DragonBoard 820c. The Status LEDs report the status of the Bluetooth and Wi-Fi devices onboard. The user LEDs are driven by the SoC directly.

---

### **User LED 1-4**

The four user LEDs are surface mount Green LEDs, 0603 size, located next to the two USB type A connector and labeled 'USER LED3 2 1 0'.

### **Bluetooth status**

The BT LED on the DragonBoard 820c is located next to the USBOTG connector; this LED reflects the status of the Bluetooth device.

### **WiFi status**

The WIFI LED on the DragonBoard 820c is located beside the BT LED, this LED reflects the status of the Wi-Fi device.

### **Power Indicator LED**

The Dragonboard 820c contains a power indicator to notify the user that power is applied.

## **12**

---

## Boot configuration

There is a 4 switch DipSwitch marked S1 located at the bottom side of the DragonBoard 820c. For normal operation, all four switches need to be set to the 'off' position.

Switch 1, 'USB BOOT', when set to 'on' position, will force boot over USB connection with a PC. This is only required for UFS boot image upgrade. Please review the proper OS User Guide for more information on this process.

Switch 2, 'SD BOOT', when set to 'on' position, will force the  $\mu$ SD, J5, to serve as the boot source for the DragonBoard 820c. You can use uSD as the main boot source or it can serve as a method for UFS boot image upgrade. Please review the proper OS User Guide for more information on this process.





Switch 3, 'SW Download Target Memory', when set to 'on' position, will force SW download/flashing to the  $\mu$ SD card, J5. When set to 'off' position, SW download will route to the UFS memory.

Switch 4, 'HUB\_SEL', when set to 'on' position, selects USB Port 0 for EDL download mode. Please review the proper OS User Guide for more information on this process.

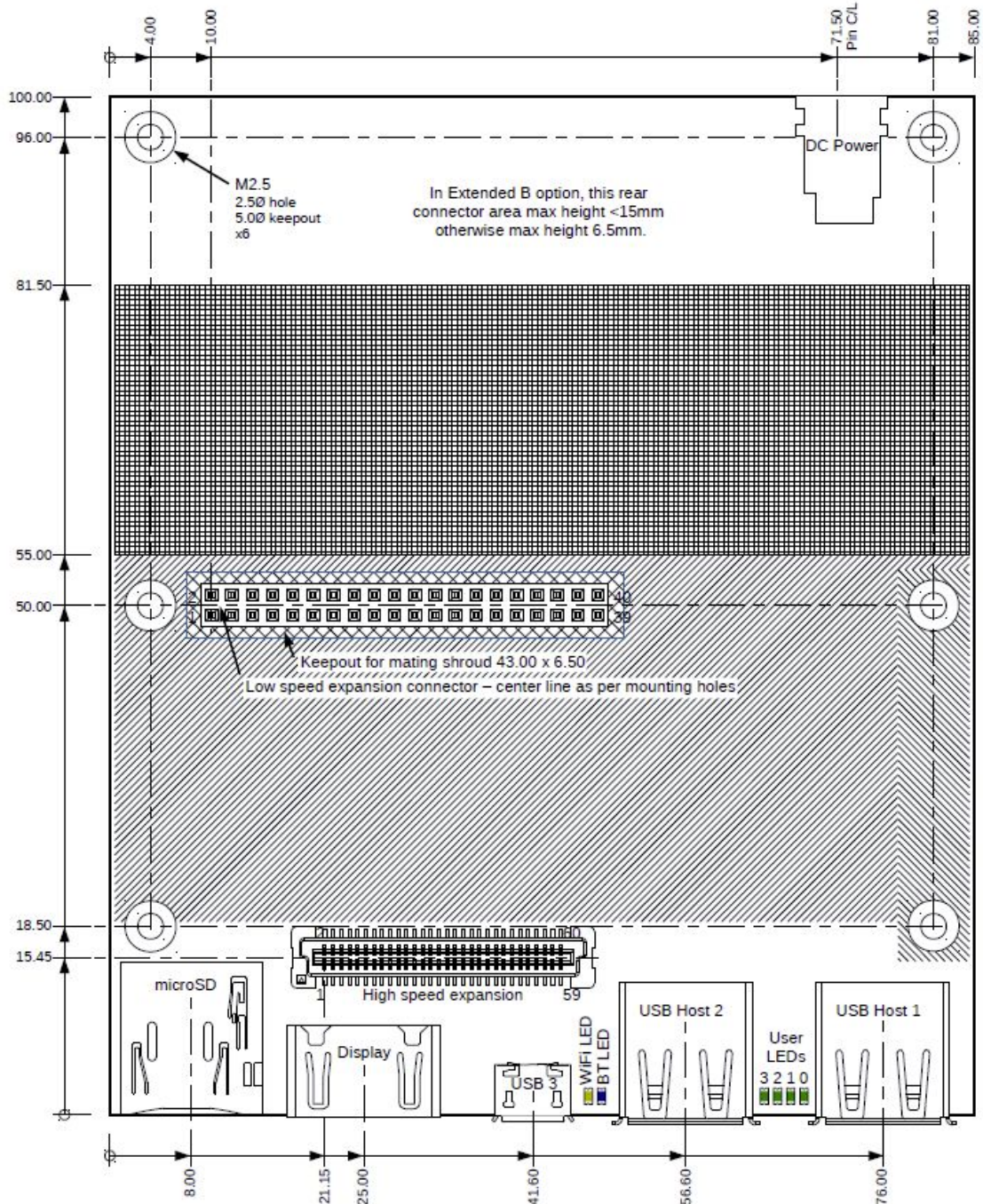

13



-  General top component max height = 6.5mm, except Type A USB Host 1 & 2 <= 7.0mm.
-  PCB/Chip WiFi antenna on top or bottom. Follow antenna specification keepout areas.
-  Top component max height = 4.0mm except user link headers and thermal management such as fan/heatsink <= 6.5mm
-  Extended area see specification for height restrictions: "Extended A" max 6.5mm or "Extended B" max 15.0mm

		
<b>TITLE: 96Boards Consumer Edition Extended Version</b>		
VERSION 1.0	SCALE 1:2	DATE 1 FEB 2015
ALL DIMENSIONS IN MM		
© 2015 Linaro		

## Mechanical specification



## Additional interfaces

The DragonBoard 820c includes interfaces which are in addition to the base 96boards CE Extended specification. These include

- J21: 24-pin audio expansion connector
- J20: Secondary High Speed Connector
- J14: Camera connector
- J16: Headset Jack
- J11: Ethernet connector

Locations of these connectors are noted on the following drawing

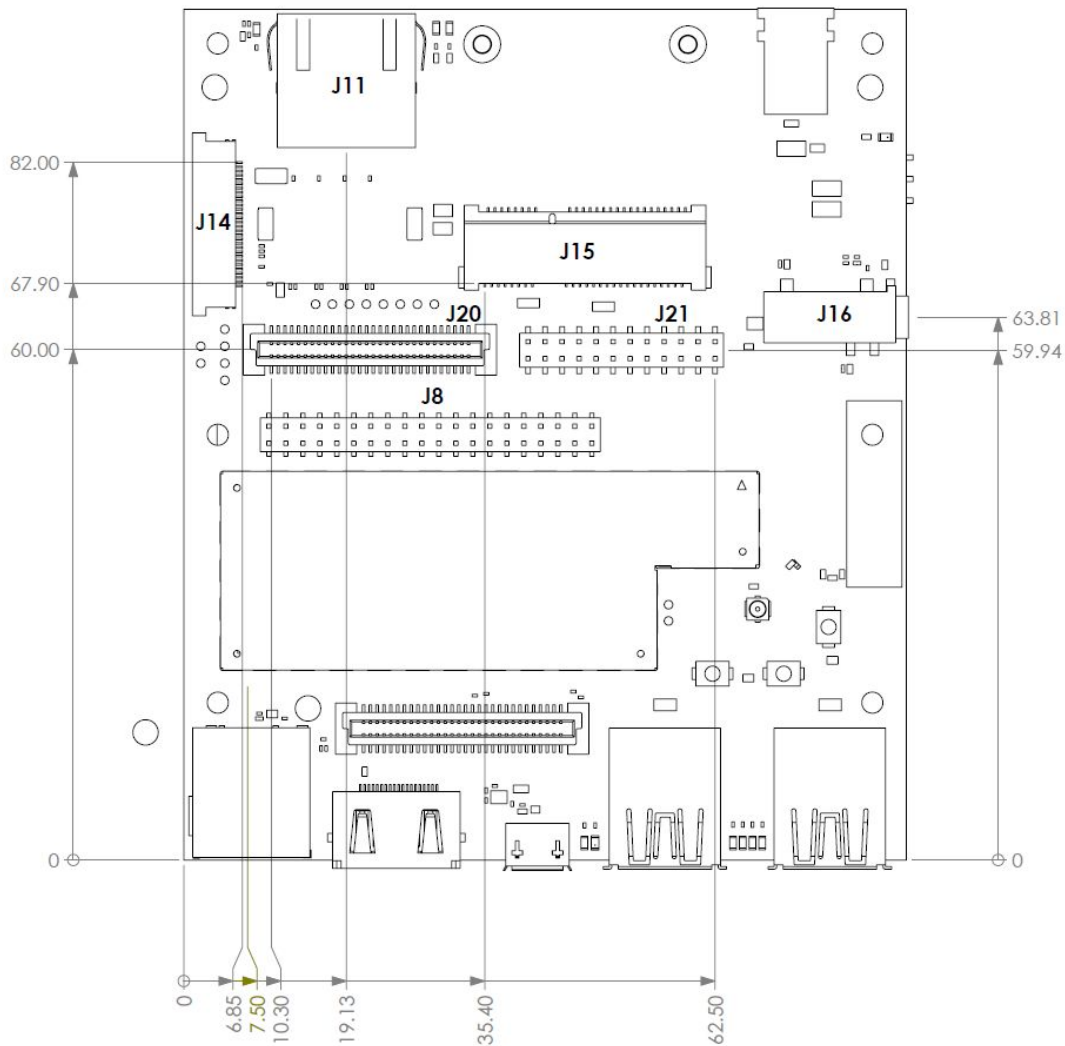



---

# License Agreement

ARROW ELECTRONICS

## EVALUATION BOARD LICENSE AGREEMENT

**By using this evaluation board or kit (together with all related software, firmware, components, and documentation provided by Arrow, "Evaluation Board"), You ("You") are agreeing to be bound by the terms and conditions of this Evaluation Board License Agreement ("Agreement"). Do not use the Evaluation Board until You have read and agreed to this Agreement. Your use of the Evaluation Board constitutes Your acceptance of this Agreement.**

### PURPOSE

The purpose of this evaluation board is solely intended for evaluation purposes. Any use of the Board beyond these purposes is on your own risk. Furthermore, according to the applicable law, the offering Arrow entity explicitly does not warrant, guarantee or provide any remedies to you with regard to the board.

### LICENSE

Arrow grants You a non-exclusive, limited right to use the enclosed Evaluation Board offering limited features only for Your evaluation and testing purposes in a research and development setting. Usage in a live environment is prohibited. The Evaluation Board shall not be, in any case, directly or indirectly assembled as a part in any production of Yours as it is solely developed to serve evaluation purposes and has no direct function and is not a finished product.

### EVALUATION BOARD STATUS

The Evaluation Board offers limited features allowing You only to evaluate and test purposes. The Evaluation Board is not intended for consumer or household use. You are not authorized to use the Evaluation Board in any production system, and it may not be offered for sale or lease, or sold, leased or otherwise distributed for commercial purposes.

### OWNERSHIP AND COPYRIGHT

Title to the Evaluation Board remains with Arrow and/or its licensors. This Agreement does not involve any transfer of intellectual property rights ("IPR") for evaluation board. You may not remove any copyright or other proprietary rights notices without prior written authorization from Arrow or its licensors.

### RESTRICTIONS AND WARNINGS

Before You handle or use the Evaluation Board, You shall comply with all such warnings and other instructions and employ reasonable safety precautions in using the Evaluation Board. Failure to do so may result in death, personal injury, or property damage.

You shall not use the Evaluation Board in any safety critical or functional safety testing, including but not limited to testing of life supporting, military or nuclear applications. Arrow expressly disclaims any responsibility for such usage which shall be made at Your sole risk.

## WARRANTY

**Arrow warrants that it has the right to provide the evaluation board to you. This warranty is provided by Arrow in lieu of all other warranties, written or oral, statutory, express or implied, including any warranty as to merchantability, non-infringement, fitness for any particular purpose, or uninterrupted or error-free operation, all of which are expressly disclaimed. The evaluation board is provided "as is" without any other rights or warranties, directly or indirectly.**

**You warrant to Arrow that the evaluation board is used only by electronics experts who understand the dangers of handling and using such items, you assume all responsibility and liability for any improper or unsafe handling or use of the evaluation board by you, your employees, affiliates, contractors, and designees.**

### LIMITATION OF LIABILITIES

**In no event shall Arrow be liable to you, whether in contract, tort (including negligence), strict liability, or any other legal theory, for any direct, indirect, special, consequential, incidental, punitive, or exemplary damages with respect to any matters relating to this agreement. In no event shall Arrow's liability arising out of this agreement in the aggregate**

---

exceed the amount paid by you under this agreement for the purchase of the evaluation board.

## **INDEMNIFICATION**

You shall, at Your expense, defend Arrow and its Affiliates and Licensors against a claim or action brought by a third party for infringement or misappropriation of any patent, copyright, trade secret or other intellectual property right of a third party to the extent resulting from (1) Your combination of the Evaluation Board with any other component, system, software, or firmware, (2) Your modification of the Evaluation Board, or (3) Your use of the Evaluation Board in a manner not permitted under this Agreement. You shall indemnify Arrow and its Affiliates and Licensors against and pay any resulting costs and damages finally awarded against Arrow and its Affiliates and Licensors or agreed to in any settlement, provided that You have sole control of the defense and settlement of the claim or action, and Arrow cooperates in the defense and furnishes all related evidence under its control at Your expense. Arrow will be entitled to participate in the defense of such claim or action and to employ counsel at its own expense.

## **RECYCLING**

The Evaluation Board is not to be disposed as an urban waste. At the end of its life cycle, differentiated waste collection must be followed, as stated in the directive 2002/96/EC. In all the countries belonging to the European Union (EU Dir. 2002/96/EC) and those following differentiated recycling, the Evaluation Board is subject to differentiated recycling at the end of its life cycle, therefore: It is forbidden to dispose the Evaluation Board as an undifferentiated waste or with other domestic wastes. Consult the local authorities for more information on the proper disposal channels. An incorrect Evaluation Board disposal may cause damage to the environment and is punishable by the law.